

Subject :

LED Outline Marker & Side Indicator Lights

Date of Issue
01/03/2004

LED's - The Benefits

LED's offer minimum of 7-8 years "fit & forget" life.

LED's current consumption is significantly less than that of a tungsten filament lamp.

LED's are covered by BMAC's standard 3 year warranty.

LED's offer greatly reduced maintenance costs compared with tungsten filament lamps.



Design Features

Completely sealed Unit

Vertical or horizontal surface mounting

Standard 84mm fixing centres for ease of retro-fitting.

Reverse polarity protection.

"Washer friendly" profile to lens cover to provide efficient cleaning effect from vehicle washing equipment.

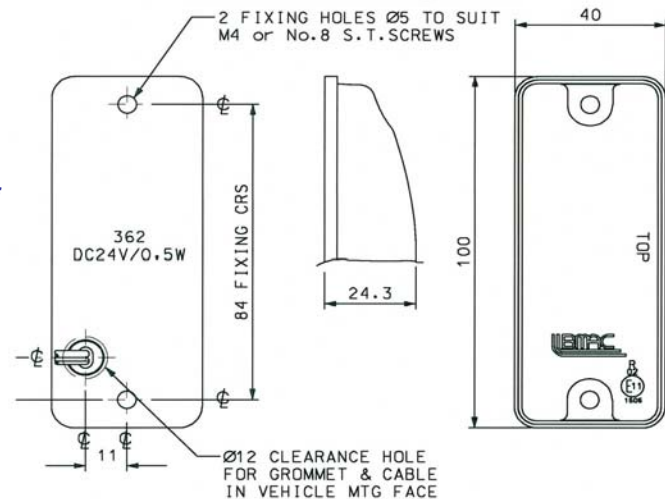

BMAC REF	PL REF	DESCRIPTION
360F24	PL12096	MARKER LIGHT - LED - WHITE FRONT - 24V
360R24	PL12095	MARKER LIGHT - LED - RED REAR - 24V
360PACK24	PL12097	MARKER LIGHT - LED - VEHICLE SET 24V (INC. PL12095 X 2 & PL12096 X 2)
362	PL13571	SIDE DIRECTION INDICATOR - LED

Volume terms available - Phone for prices
Telephone Order Line - 01274 531531 Fax Order Line : 01274 531088
email : sales@partline.co.uk www.partline.co.uk